

# Instruction Manual



FY-3W

---

Our equipment is approved by the following car manufacturers (China)



# Contents

---

1. Precautions	1
2. Specifications	2
3. Installation	3
4. Controls	4
5. Operation	5
6. Troubleshooting	
1) Troubleshooting	6
2) Lamp Tube Replacement	7
7. Exploded View	8
8. Circuit Diagram	9

# 1. Precaution

---

1. Read this manual carefully before installing or servicing this equipment.
2. This equipment is designed for paint drying applications. Adjust to the correct temperature and check minimum safe distance from heat source when using. Improper use can cause paint surface damage.
3. Installation and servicing must be performed by a qualified technician or service agency.
4. The system has been designed for easy installation, low operating cost and minimum maintenance. The warranty does not cover lamp tube defects resulting from misuse or improper operation.
5. Disconnect power source when the equipment is not in use for a long period.
6. The lamp tube should not be perpendicular to the ground when the equipment is in operation. Otherwise, it will shorten the service life of the lamp tube.

Model	FY-3W
Input Power Source	Single Phase 220V 50/60Hz
Input Power (W)	3 × 1100
Curing Area (mm)	1200 × 1000
Temperature (°C)	40 - 100
Time Setting	0 - 99mins Adjustable
Light Intensity (%)	10 - 100

## 3. Installation

The shortwave infrared curing lamp is divided into 3 parts (a base, a column and a cassette).

1) Installation of the base.

- a. Open the packing of the base.
- b. Install the four wheels on the base respectively and tighten up the screws. Usually, the wheels with brakes should be mounted on the rear of the base.

2) Installation of the column.

- a. Open the packing of the column.
- b. Put the column vertically on the top of the base, directly engage the screw holes and tighten up using the screws.
- c. Connect the support arm with the column for supporting the cassette.
- d. Connect the lifter with the column to control the up and down movement of the cassette.

3) Installation of the cassette.

- a. Open the packing of the cassette with care.
- b. Connect cassette with support arm and tighten up with the screws.
- c. Connect control wires and adjust the angle of cassette.

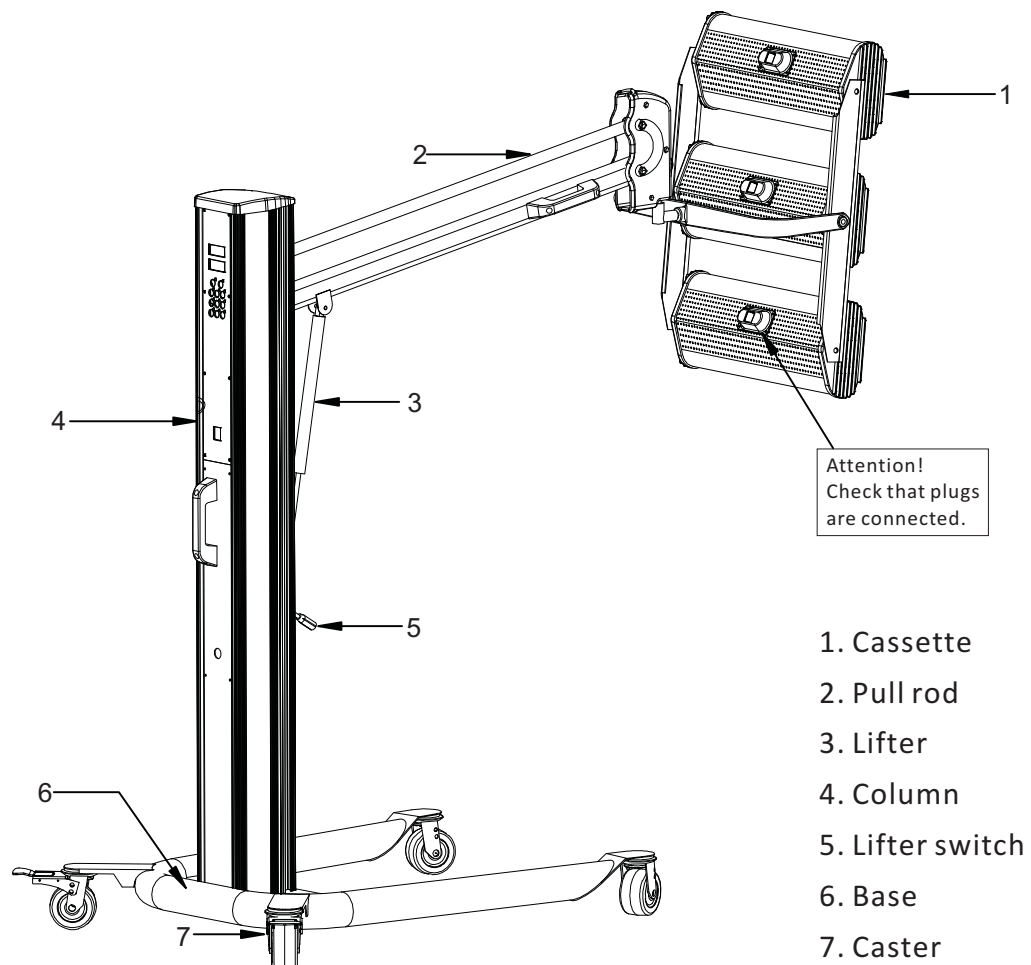

## 4. Controls

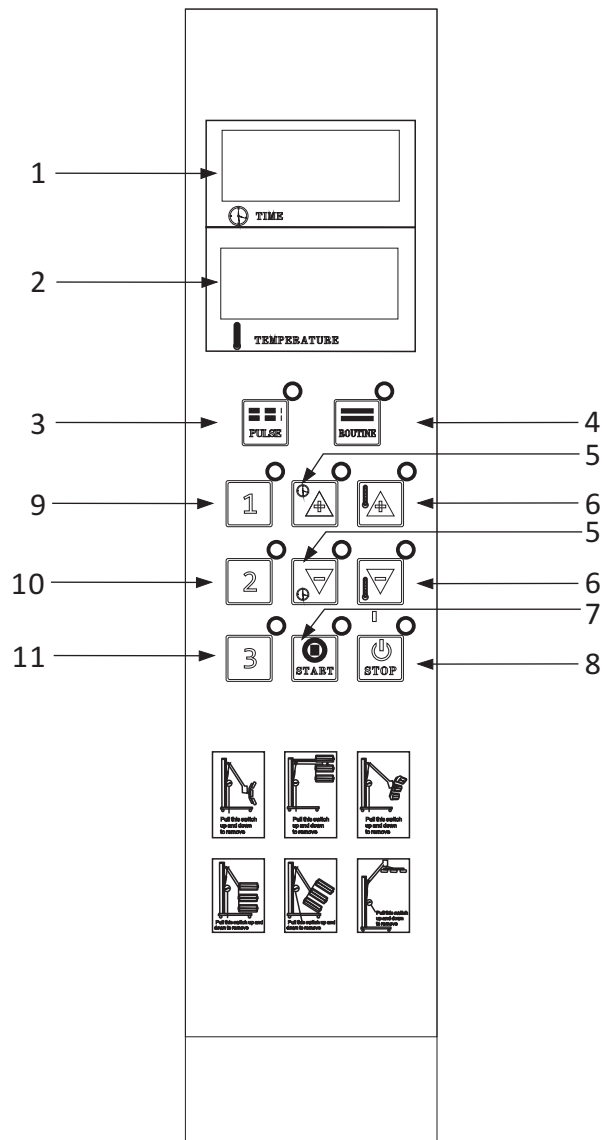

1. Time Display
2. Temperature Display
3. Pulse Paint Curing
4. Routine Paint Curing
5. Time Adjustment
6. Temperature Adjustment
7. Start
8. Stop
9. Lamp 1 Selector
10. Lamp 2 Selector
11. Lamp 3 Selector

Circuit breaker must be installed

## 5. Operation

1. Connect input power cord (should be no less than 4mm<sup>2</sup> copper cord).
2. Turn on the machine, digital displays will show figures.
3. Select "Routine" or "Pulse".
4. Set temperature and time according to the requirements of paint being cured. The display will show data. Pulse curing helps to achieve more lustrous results.
5. To achieve the best curing result, the lamp should be parallel with the paint surface.
6. Adjust the distance from heat source to the paint surface. Usually, a distance of 30-50cm is best.
7. When paint curing, the paint surface must be clean, without water and impurities.
8. Turn off the equipment after using. Place the equipment in a safe place to avoid damage to the lamp tube.

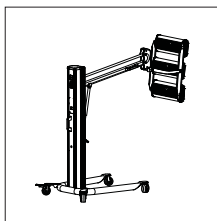

Install machine

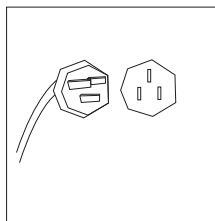

Connect input power

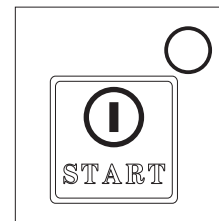

Switch on

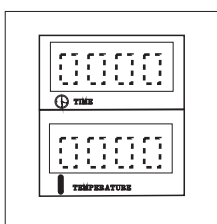

Digital display data

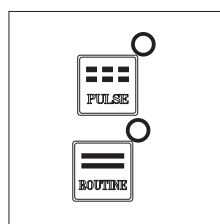

Select "Pulse" or "Routine"

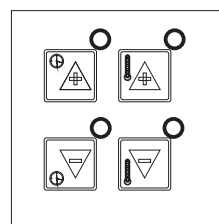

Set "Temperature" and "Time"

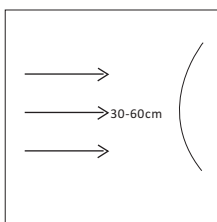

Keep heat source parallel to paint surface a distance of 30-60cm

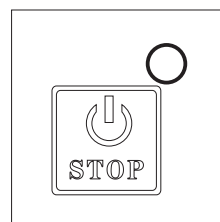

Switch off the machine after curing

## 6. Troubleshooting

### 1. Troubleshooting

<b>PROBLEM</b>	<b>CAUSE</b>	<b>SOLUTION</b>
Lamp tube does not work	1) Lamp tube damaged 2) Lamp tube not plugged in 3) Control silicon damaged	1) Check lamp tube 2) Check connections 3) Check control silicon
Lamp tube does not turn off	1) Control silicon damaged	1) Check control silicon
Digital display is blank or is incomplete	1) Unplugged flat wire in circuit board 2) Digital display is damaged	1) Check flat wire 2) Check digital display
Time and temperature cannot be adjusted	1) Switch imbalance 2) Keyboard has exclusion	1) Check the installation of switch 2) Check keyboard exclusion



## 6. Troubleshooting

### 2. Lamp Tube Replacement

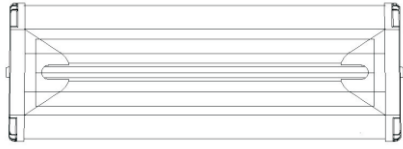

(1)

1. Prepare cassette for replacement



(2)

2. Remove the grille of cassette

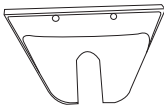

(3)

3. Remove the plates from both ends of the cassette

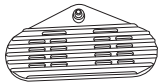

(4)

4. Remove the fixed plates from both ends of the cassette



(5)

5. Loosen fixed screws and cut off connections, the lamp can be replaced



(6)

6. Reverse the steps above to install the new lamp

## 7. Exploded View

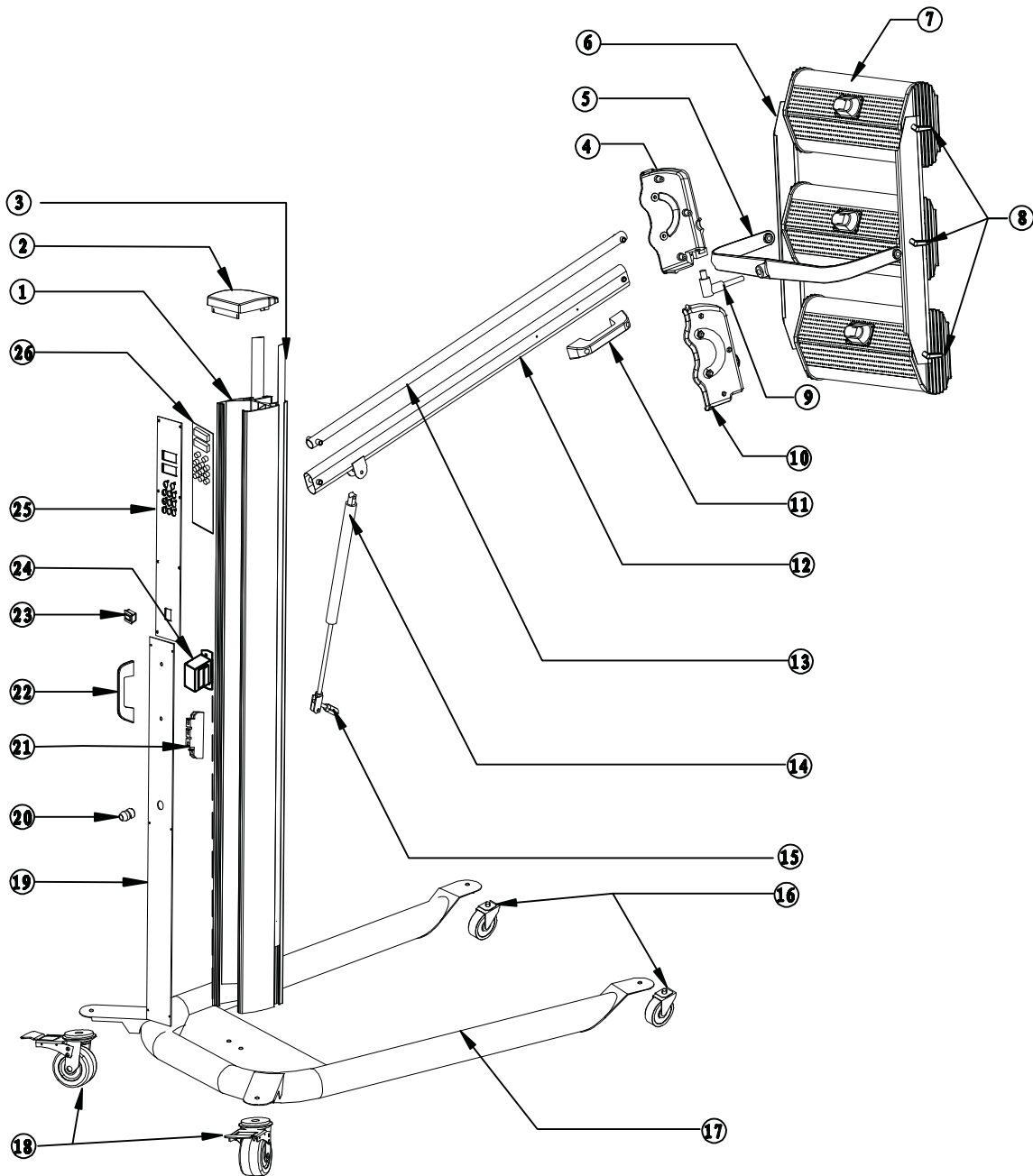

No.	Name	No.	Name	No.	Name	No.	Name
①	Upright post	⑨	Connecting axle	⑰	U-type base	⑲	Cover plate (upper)
②	Top cover	⑩	Connector (right)	⑱	Back wheel	⑳	Circuit board
③	Plastic band	⑪	Handle	⑲	Cover plate (lower)		
④	Connector (left)	⑫	Lower connecting rod	⑳	Flange		
⑤	Bracket	⑬	Upper connecting rod	㉑	Control silicon		
⑥	Clamping bar	⑭	Lifter	㉒	Handle		
⑦	Cassette	⑮	Lifter handle	㉓	Power switch		
⑧	Plastic nut	⑯	Front wheel	㉔	Transformer		

## 8. Circuit Diagram

